

March 17, 1959

J. H. ENGELMAN ET AL

2,878,407

ION CONTROL MEANS

Filed April 16, 1956

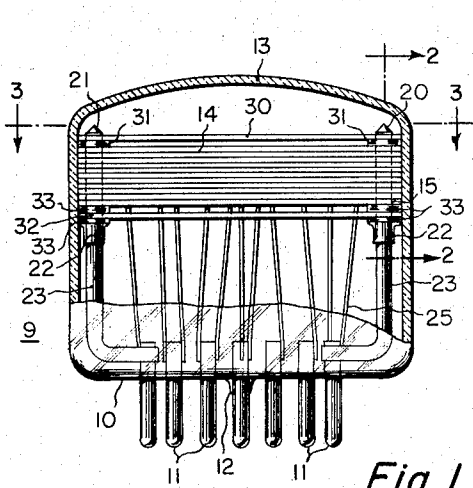

Fig. 1

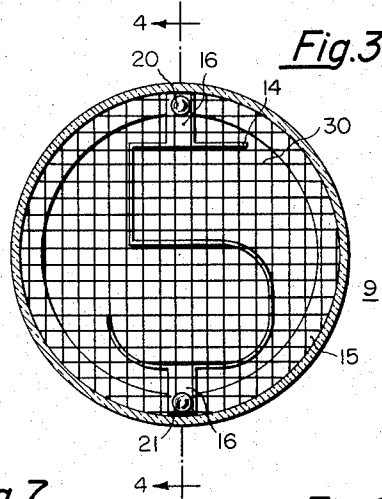

Fig. 3

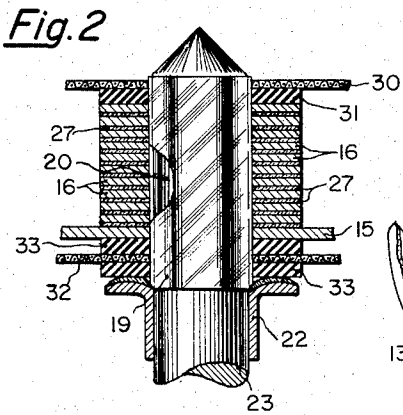

Fig. 2

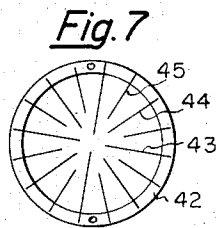

Fig. 7

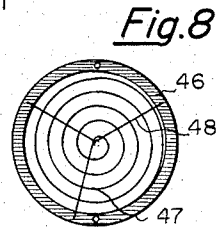

Fig. 8

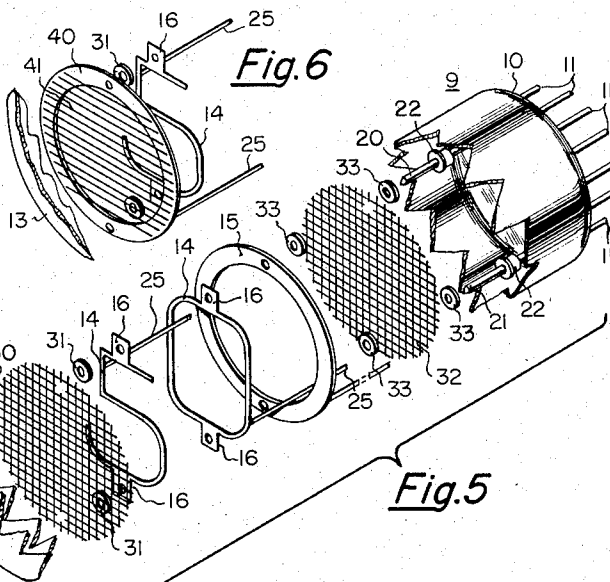

Fig. 5

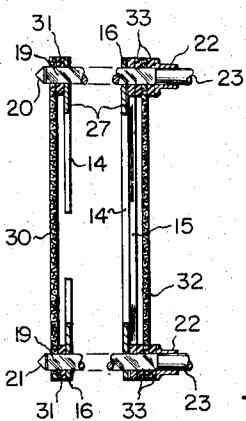

Fig. 4

INVENTORS
JOSEPH H. ENGELMAN
LEO R. LANDREY
VICTOR LEGENDRE
BY Charles F. Carroll, Jr.
ATTORNEY

1

2,878,407

ION CONTROL MEANS

Joseph H. Engelman, Paoli, and Leo R. Landrey, Wayne, Pa., and Victor J. Le Gendre, Roselle Park, N. J., assignors to Burroughs Corporation, Detroit, Mich., a corporation of Michigan

Application April 16, 1956, Serial No. 578,371

5 Claims. (Cl. 313—109.5)

The present invention relates to space discharge tubes and more particularly to indicating tubes of the cathode glow gas discharge type.

In gas discharge indicating tubes, wherein any one of a plurality of cathodes, representing numbers, letters or other characters, can be selected to produce a luminous outline, it has been found, after a period of operation considerably less than the expected life of such a tube, that the glow outline not only loses its sharpness but will even become completely blacked out as viewed from the viewing end of the tube. This supposed contamination or deterioration of the cathode in reality is now known to be caused by sputtering of the material of the cathode so that the sputtered metal collects upon the internal glass surface of the envelope to produce, not only a severe darkening of that surface, but also after a length of time renders the viewing end of the tube opaque. Furthermore the sputtering also deposits upon the insulation between the electrodes to cause the insulation to become conducting and so interfere with the required cathode selection and operation. In tubes other than of this indicating type sputtering may impair operation particularly on the inner surface and at the stem end of the tubes.

An object of the present invention is to provide a tube construction wherein the foregoing disadvantages are overcome.

Another object is to provide a gas discharge tube wherein metal sputtering from a cathode is prevented from depositing upon the envelope of the tube.

Another object is to provide a gas discharge tube wherein the insulation between electrodes is protected from cathode metal sputtering to thereby prevent the formation of a conducting surface upon the insulation.

A further object is to provide a gas discharge tube of the cathode glow type for indicating by glow any one of a plurality of numbers or characters arranged in the tube envelope for viewing from an end face wherein metal sputtered from the cathodes is trapped and prevented from depositing upon the viewing face.

A still further object is to provide a gas discharge tube of the cathode glow type for indicating by glow any one of a plurality of numbers or characters arranged in the tube envelope wherein metal sputtered from the cathodes is trapped and prevented from depositing upon the envelope base.

In the accompanying drawings:

Fig. 1 is a side elevation view of a tube embodying one form of the present invention and having the glass envelope broken away to expose the interior to view;

Fig. 2 is an enlarged sectional detail taken along line 2—2 of Fig. 1 and showing one of the electrode supporting studs in assembled condition traversing the cathode supporting tabs;

Fig. 3 is a section view taken on line 3—3 of Fig. 1;

Fig. 4 is a section view taken on line 4—4 of Fig. 3;

Fig. 5 is an exploded perspective view of the tube assembly showing several but not all of the cathode charac-

2

ters and only the ends of the envelope with which the assembly is associated.

Fig. 6 is an exploded view of the forward part of a different electrode assembly embodying the invention;

Fig. 7 is a plan view of another form of electric screen electrode; and

Fig. 8 is a plan view of still another form of electric screen electrode.

Referring to the drawings one type of tube is shown having the invention assembled therein, such tube being illustratively that disclosed and claimed in the pending application of Herbert J. Hampel, Serial No. 552,748, filed December 13, 1955, and assigned to the assignee of the present invention. In this instance the tube comprises a transparent envelope 9, which has been evacuated and then filled to a low pressure with a gas such as neon, making the tube suitable for glow operation. The envelope 9 has a sealed base 10, which may be a conventional base disc or button of glass through which a plurality of leads or contact pins 11 project to connect the various electrodes of the glow tube into control and indicating circuits. The axes of the pins 11 are parallel to each other and to the longitudinal axis of the envelope 9. The pins are also preferably arrayed about the longitudinal axis of the envelope. Once the tube has been evacuated and the gas, for glow operation, has been introduced, the tube is sealed off at vacuum seal 12, preferably located in the base 10 so as to leave a transparent and unobstructed viewing face 13 at the other end of the envelope 9.

The assembly of cathodes 14, anode 15 and supporting studs 20 and 21, are positioned within the envelope 9 very close to the transparent end face 13. The studs 20 and 21 are preferably disposed at diametrically opposite sides of the tube envelope. Each stud is coated with insulation 19 and is welded at one end to a collar 22 bonded to a support member 23 which in turn is bent and then welded to a base pin or contact pin 11, whereby the entire assembly is rigidly supported. Each cathode 14 is provided with an individual lead 25 which provides electrical connection to the particular base pin 11. In addition, each cathode 14 has an upper and lower apertured tab 16, the upper being supported upon the stud 20, and the lower being supported upon the stud 21 to form a compact stack, the respective tabs 16 being insulated from one another by insulation 27. The cathodes are thus oriented in substantially parallel planes facing the viewing window and transverse to the axis of the tube envelope and to the axes of the pins 11. In the usual operation of this type of indicating tube, a single cathode character is connected through its lead 25 and pin 11 to a suitable source of electrical potential for causing it to glow. This glow is distinctly visible even though there may be several non-glowing cathode characters between it and the viewing end of the tube. While the foregoing assembly is specifically the indicating tube of the stated pending patent application, it is to be understood it is only an example of a tube to which the invention is applicable. Broadly therefore, the invention is for association with any space discharge tube in which sputtering of metal has been found to impair the tube operation.

As a means for preventing the deposition of sputtered metal upon the inner surface of the envelope 9, or upon insulation adjacent the tube electrodes, a reticulated metal screen 30 composed of crossing fine wires is mounted within the envelope 9 to extend transversely thereof between the viewing face 13 and the juxtaposed cathode assembly, but electrically isolated therefrom. Where the screen 30 is to be supported from a cathode-anode assembly, different from that shown, suitable insulation is of course required. In the present instance where the electrodes are supported by the studs 20 and 21 which

3

pass through the tabs 16, insulating washers 31, such as mica, are disposed between the screen 30 and the adjacent cathode, which in this instance is the numeral "5." In a different arrangement of the numbers, any other numeral would take the place of that here shown opposite the screen 30. As so supported the screen 30 serves as a trap for metal sputtered from the cathodes.

Also as a means to prevent an impairing deposition on the electrode leads, as well as on the internal surface and base of the envelope 9, a second reticulated screen 32 is supported by the studs 20 and 21 in juxtaposed relation to the anode 15 but insulated from the adjacent anode 15 and the collar 22 by washers 33 of mica or other insulating material fitted about the respective supporting studs 20 and 21.

Screens 30 and 32 have proven to be effective in preventing sputtered metal from reaching the viewing surface of envelope 13 both when they are "floating" electrically, i. e., unconnected electrically to a source of potential, and also when they are connected to the positive side of a voltage supply and function as an anode in place of ring 15. When screens 30 and 32 are "floating" they will acquire the electrical charge of the sputtered particles, whatever their polarity may be, by virtue of capturing such particles in collisions with them and will exert an electrostatic repulsion force on the passage of additional charged particles through the screens and to the viewing face or to the connecting pins. This inhibits any further deposit of such particles. When the screens 30 and 32 are strongly charged as an anode electrode, the depositing process is checked in what appears to be a different manner. This may be explained by considering that the particles are the outer surface of some electrode, probably the glowing electrode, just before they are sputtered off, and while still in contact therewith experience an induced negative charge from the anode-to-cathode electrical field. The particles carry this negative charge with them when they move, and are attracted to the anode screens 30 and 32 where they are captured before they can do any harm to the viewing face or to the insulation between connecting pins. Although the reticulated screen 30 is between the observer and the glowing cathode, the fine wires of the screen do not visibly effect the view of the cathode.

Fig. 6 shows a variation on screen 30. Ring 40 supports a closely spaced parallel succession of very fine wires 41, and has mounting holes for support upon pins 20 and 21. A connecting lead 25' is provided on ring 40 for connecting anode potential to it in the assembled tube. With anode potential on wires 41 a positive voltage plane is established in the plan of ring 40, yet visibility is unimpaired due to the fineness of wires 41. Screen 32 can be similarly constructed.

Fig. 7 shows another form of inhibiting screen comprising a ring 42 with wires 43, 44 and 45 of various lengths extending radially inward so as to approximate a planar electrode in the plane of ring 42. Ring 42 can be used in place of ring 40.

Fig. 8 shows yet another form of screen comprising a ring 46 with a helical wire 47 and radial supporting wires 48 as another useful configuration to provide a planar screening electrode.

While in the foregoing the mounting means for the cathode-anode assembly is illustrated by a supporting stud construction, the invention is not to be considered as so limited as obviously other supporting means can serve the purpose as well, the desideratum being that both screens are to be electrically isolated from both the cathodes and the anode.

It will now be apparent that a complete unitary glow discharge tube has been devised wherein selected illuminated numbers or characters can be distinctly viewed from an end of the tube at all times while the tube is operating. Such distinct viewing is made possible by providing strategically located metal traps, in this in-

4

stance, screens upon which discharged ions collect as a metal deposit instead of, as heretofore, upon the inner surface of the tube. Thus by the present invention darkening of the tube surface by such deposits is prevented and the envelope remains always clear and unobstructed.

What is claimed is:

1. An indicating tube of the glow lamp type comprising a gas-filled envelope having a base and a portion thereof constituting a transparent viewing window and a plurality of contact pins extending through said base, said pins having their axes parallel to each other and to the longitudinal axis of said envelope, said pins being arrayed about said longitudinal axis of the tube envelope, a plurality of plane glow cathodes mounted in a stack within said envelope and having the active portions thereof formed in accordance with outline representations of different characters, said cathodes being oriented in substantially parallel planes transverse to the longitudinal axis of the envelope and to the axes of the pins, a pair of support posts within said envelope having an insulating coating and supporting said cathodes in stacked relationship with said cathodes facing said viewing window, said cathodes each including mounting tabs extending outside of the area of the character-formed portion thereof and mounted on said support posts, insulating washers mounted on said support posts and insulating said cathodes from each other, said support posts being secured to said base of said envelope, an electrical lead secured to each of said cathodes and to a contact pin, and a transparent shield electrode between said cathodes and said viewing window for substantially preventing metal sputtered from said cathodes from falling on said viewing window, said shield electrode comprising a fine mesh wire screen and operable as an anode with respect to said cathodes.

2. An indicating tube of the glow lamp type comprising a gas-filled envelope having a base and a portion thereof constituting a transparent viewing window, a plurality of contact pins extending through said base, said pins having their axes parallel to each other and to the longitudinal axis of said envelope, said pins being arrayed about said longitudinal axis of the tube envelope, a plurality of plane glow cathodes mounted in a stack within said envelope and having the active portions thereof formed in accordance with outline representations of different characters, said cathodes being oriented in substantially parallel planes transverse to the longitudinal axis of the envelope and to the axes of the pins, an anode within said envelope for ionizing the gas in response to a suitable potential difference between said anode and a selected one of said cathodes, a pair of support posts within said envelope having an insulating coating and mounting said cathodes and said anode in stacked relationship with said cathodes facing said viewing window, said cathodes each including mounting tabs extending outside of the area of the character-formed portion thereof and mounted on said support posts, insulating washers mounted on said support posts and insulating said cathodes and said anode from each other, said support posts being secured to said base of said envelope, an electrical lead secured to said anode and each of said cathodes and terminating at a contact pin, and a transparent shield electrode between said cathodes and said viewing window for substantially preventing metal sputtered from said cathodes from falling on said viewing window, said shield electrode comprising a fine mesh wire screen.

3. An indicating tube of the glow lamp type comprising a gas-filled envelope having a base and a portion thereof constituting a transparent viewing window, a plurality of contact pins extending through said base, said pins having their axes parallel to each other and to the longitudinal axis of said envelope, said pins being arrayed about said longitudinal axis of the tube envelope, a plurality of plane glow cathodes mounted in a stack within said envelope

5

and having the active portions thereof formed in accordance with outline representations of different characters, said cathodes being oriented in substantially parallel planes transverse to the longitudinal axis of the envelope and to the axes of the pins, a pair of support posts within said envelopes having an insulating coating and mounting said cathodes in stacked relationship with said cathodes facing said viewing window, said cathodes each including mounting tabs extending outside of the area of the character-formed portion thereof and mounted on said support posts, insulating washers mounted on said support posts and insulating said cathodes from each other, said support posts being secured to said base of said envelope, a separate electrical lead secured between each of said cathodes and a contact pin, and a wire screen electrode means between said cathodes and said viewing window and between said cathodes and said contact pins for substantially preventing metal sputtered from said cathodes from falling on said viewing window and on said pins, said wire screen electrode means being operable as an anode with respect to said cathodes.

4. An indicating tube of the glow lamp type comprising a gas-filled envelope having a base and a portion thereof constituting a transparent viewing window, a plurality of contact pins extending through said base, said pins having their axes parallel to each other and to the longitudinal axis of said envelope, said pins being arrayed about said longitudinal axis of the tube envelope, a plurality of plane glow cathodes mounted in a stack within said envelope and having the active portions thereof formed in accordance with outline representations of different characters, said cathodes being oriented in substantially parallel planes transverse to the longitudinal axis of the envelope and to the axes of the pins, a pair of support posts within said envelope having an insulating coating and mounting said cathodes in stacked relationship with said cathodes facing said viewing window, said cathodes each including mounting tabs extending outside of the area of the character-formed portion thereof and mounted on said support posts, insulating washers mounted on said support posts and insulating said cathodes from each other, said support posts being secured to said base of said envelope, an electrical lead secured between each of said cathodes and to a contact pin, and a transparent shield electrode mounted on said support posts at the top

6

of said stack between said cathodes and said viewing window for substantially preventing metal sputtered from said cathodes from falling on said viewing window, said shield electrode being insulated from said cathode electrodes, and an auxiliary shield electrode mounted on said support posts between said cathodes and said base of said envelope and insulated from said cathodes.

5. An indicating tube of the glow lamp type comprising a gas-filled envelope having a base and a portion thereof constituting a transparent viewing window and a plurality of contact pins extending through said base, said pins having their axes parallel to each other and to the longitudinal axis of said envelope, said pins being arrayed about said longitudinal axis of the tube envelope, a plurality of plane glow cathodes mounted in a stack within said envelope and having the active portions thereof formed in accordance with outline representations of different characters, said cathodes being oriented in substantially parallel planes transverse to the longitudinal axis of the envelope and to the axes of the pins, a pair of support posts within said envelope having an insulating coating and mounting said cathodes in stacked relationship with said cathodes facing said viewing window, said cathodes each including mounting tabs extending outside of the area of the character-formed portion thereof and mounted on said support posts, insulating washers mounted on said support posts and insulating said cathodes from each other, said support posts being secured to said base of said envelope, an electrical lead secured between each of said cathodes and a contact pin, and a pair of wire screen electrodes mounted on said support posts parallel to said cathodes and insulated from said cathodes and substantially enclosing said stack of cathodes, one of said screen electrodes being at the top of the stack between said cathodes and said viewing window and the other being at the bottom of said stack between said cathodes and said base of said envelope.

References Cited in the file of this patent

UNITED STATES PATENTS

1,971,147	Whitman	Aug. 21, 1934
2,429,118	Besser	Oct. 14, 1947
2,500,929	Chilowsky	Mar. 21, 1950
2,618,760	Hancock et al.	Nov. 18, 1952