

June 1, 1937.

F. L. SHELOR

2,082,724

ILLUMINATED INDICATOR FOR HOUSE NUMBERS OR THE LIKE

Filed Feb. 13, 1936

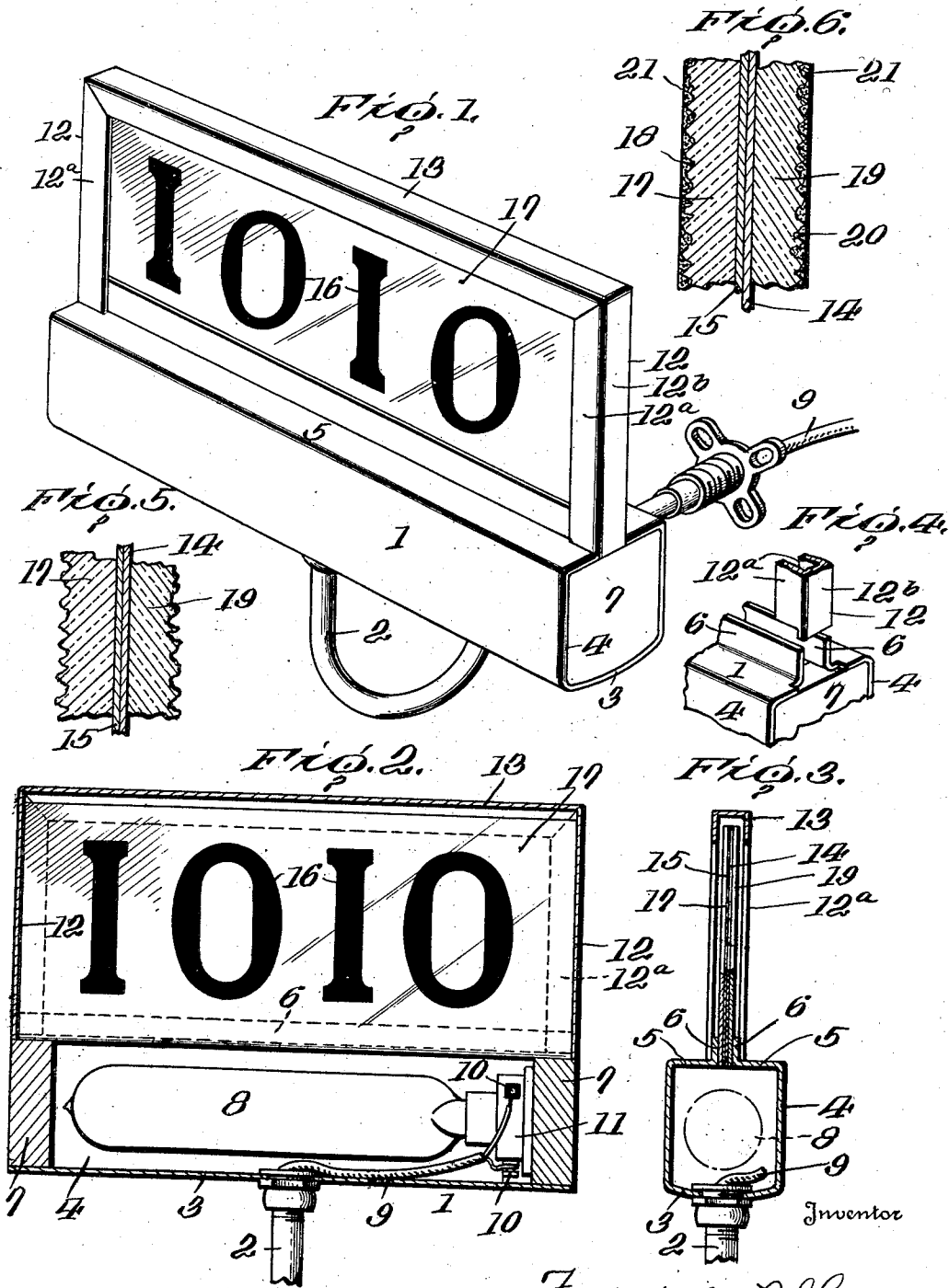

Inventor

Frederick L. Shelor

By

Mason & Porter

Attorneys

UNITED STATES PATENT OFFICE

2,082,724

ILLUMINATED INDICATOR FOR HOUSE NUMBERS OR THE LIKE

Frederick L. Shelor, Sandston, Va.

Application February 13, 1936, Serial No. 63,813

5 Claims. (Cl. 40—130)

The invention relates to new and useful improvements in an illuminated indicator which may be used for indicating a house number, room numbers in an office building, the names of streets and the like.

An object of the invention is to provide an indicator which may be cheaply made and wherein the characters which are illuminated are made clear and distinct from all angles of vision.

A further object of the invention is to provide an illuminated indicator of the above type wherein the rays of light for illuminating the indicator are projected on to the indicator from one edge thereof, and are reflected and dispersed over the surface containing the characters to be illuminated by the rear face of a frosted glass surface through which said characters are viewed.

These and other objects will in part be obvious and will in part be hereinafter more fully disclosed.

In the drawing which shows by way of illustration one embodiment of the invention—

Figure 1 is a perspective view showing the illuminated indicator embodying the invention;

Fig. 2 is a longitudinal sectional view through the indicator shown in Fig. 1;

Fig. 3 is a transverse sectional view through the indicator shown in Fig. 1;

Fig. 4 is a detail in perspective showing the manner of joining the frame supporting the characters to be illuminated on the housing for the illuminating means;

Fig. 5 is a sectional view on an enlarged scale through the glass panels and the strip carrying the characters to be illuminated, and

Fig. 6 is a view similar to Fig. 5, but showing a slightly modified form of the invention.

Many efforts have been made to produce an indicator for numbers, letters and other forms of characters wherein the rays of light for illuminating the characters are caused to pass edgewise through a glass panel through which the characters are viewed. Such devices have not been efficient for the reason that such a large proportion of the illuminating rays do not contact with the surface bearing the characters to be illuminated. One of the purposes of the present invention is to provide an illuminated indicator wherein the surface of the glass panel through which the characters are viewed is so conditioned as to become a reflecting surface as well as a dispersing surface so that the illuminating rays are directed uniformly over the strip containing the characters to be illuminated.

In carrying out the invention, a housing 1 is

provided which may be mounted on a suitable bracket arm 2 in any desired way. This housing, as shown, is substantially rectangular in cross section, and the bracket arm 2 is firmly attached to the bottom member 3 of the housing. The side walls 4, 4 of the housing are bent inwardly at the upper edges thereof so as to provide two top members 5, 5. Each top member 5 is provided with upwardly projecting flanges 6, and these flanges are normally spaced from each other. Each end of the housing is provided with a closure cap 7 which extends some little distance into the housing, as shown in Fig. 2, and the side walls 4, 4 and the top members 5, 5 are unattached to this end closure. All of the parts described are opaque so that no light passes therethrough. The parts are preferably made of metal which may be enameled in any desired color for decorative purposes. Located within this housing is a lighting tube 8 which may be of any desired form. The current for the lighting tube is supplied through wires 9 which lead through the bracket arm from the source of supply and are attached to terminals 10, 10 associated with a socket piece 11 to which the lighting tube is attached. This socket piece is attached to one of the end closure members 7. The member to which it is attached may be detachably secured to the housing in any suitable way.

A U-shaped frame is provided for supporting the strip on which the characters to be illuminated are placed. This U-shaped frame consists of two end members 12, 12 which are connected at their upper ends by a cross member 13. The end members and the cross member are also U-shape in cross section, as indicated in Fig. 4, so that each end member includes side pieces 12a, 12a which are spaced from each other, and a connecting piece 12b. This connecting piece 12b is preferably extended slightly below the edges of the side pieces 12a, 12a.

As shown in the drawing, the indicator is constructed and adapted to contain two strips with characters thereon, which may be viewed, respectively, from opposite sides of the indicator. It is understood, however, that a single strip may be used when it is desired to view the indicator only from one side thereof. One of the strips is indicated at 14 in the drawing, and the other is indicated at 15. The strip is provided with characters which are indicated in the drawing at 16. This strip is of opaque material, preferably paper, and likewise, the characters are of opaque material, and preferably paper. The characters, 55

however, are of paper having different light reflecting properties than the surface of the strip. For example, the strip may be black so that it absorbs the light rays, and the characters may be white so as to reflect the light rays, or the reverse characters may be used. It is only essential that the character and the strip on which it is mounted shall have different light reflecting properties, so that when illuminated, the characters will be made visible. In front of the strip 15 is a glass panel 17. This glass panel 17 is preferably of relatively thick glass, such as plate glass. The front face of the glass panel is frosted as indicated at 18. The frosted surface may be obtained by grinding or by etching, or in any other suitable way. It is essential, however, that the surface shall be broken into a multitude of minute surfaces which are at an angle to each other. The characters are on the front face of the strip and are in contact with the rear face of the glass panel 17. Also contacting with the strip 14 is a glass panel 19 with a frosted surface 20. The glass panels and the strips are placed in this supporting frame and then the supporting frame is attached to the housing 1. The upstanding flanges 6, 6 are housed within the side pieces 12a, 12a and the piece 12b extends down over the end closure 7 to aid in holding it in place. This provides a very cheap method of closing the housing against the end closures and providing a housing which is completely closed, except for the slot between the upstanding flanges 6, 6. The glass panels fill this slot, so that all of the light rays passing from the housing 1 must pass through the glass panels. The light rays passing up into the glass panel 17 will contact with the inner face of the frosted surface, and as the rays contact with the minute surfaces angularly disposed relative to each other, the rays of light will be dispersed and will be reflected onto the characters for illuminating the same. Inasmuch as the characters to be illuminated are in contact with the rear face of the glass panel, the rays of light are immediately absorbed as they leave the glass panel, or turned back and reflected through the frosted surface to the observer. This results in a very clear-cut illuminated character which can not only be viewed from directly in front, but from any angle of approach to a position directly in front of the indicator. This makes the indicator very efficient for use in the indicating of the names of streets, and also for use in indicating the number of a house, or the number of a room in an office building.

The characters on the strip 14 are only seen, of course, from the opposite side of the indicator, and as has already been noted, only one strip and one glass panel may be used in the indicator, if desired.

In Fig. 6 of the drawing, the glass panel as shown has been treated with a transparent lacquer which is indicated at 21. This transparent lacquer is distributed over the frosted surface of the glass in a sufficient quantity to substantially fill all the minute cavities in the frosted surface. This reduces the dispersion of the rays of light as they are reflected from the illuminated surface of the strip. For example, a ray of light reflected from the illuminated surface contacting with the angularly arranged inner face of a cavity will be refracted, and then as it passes through the transparent lacquer, and as it leaves the outer surface of the lacquer, it will be brought back more nearly into a direction of movement perpendicular to the plane of the outer face of the

glass panel. This transparent lacquer increases the efficiency of the illumination of the characters, while the inner face of the frosted surface greatly increases the efficiency of the reflected rays which are distributed and dispersed over the surface to be illuminated.

It is obvious that many changes in the details of construction and the arrangement of the parts may be made without departing from the spirit of the invention as set forth in the appended claims.

Having thus described the invention, what I claim as new and desire to secure by Letters Patent, is—

1. An illuminated indicator comprising a glass panel, a strip having characters on one face thereof, the characters and strip on which they are mounted having different light absorbing properties, said strip being disposed relative to the glass panel so that the characters are visible through said glass panel, the outer face of said glass panel being frosted, and means for housing and directing illuminating rays through the edge of the glass panel into the glass and against the rear face of said frosted surface of the glass panel whereby said rays are dispersed and reflected on to the strip and characters to be illuminated.

2. An illuminated indicator comprising a glass panel, a strip having characters on one face thereof, the characters and strip on which they are mounted having different light absorbing properties, said strip being disposed relative to the glass panel so that the face thereof bearing the characters contacts with the rear face of said glass panel, the outer face of said glass panel being frosted, and means for housing and directing illuminating rays through the edge of the glass panel into the glass and against the rear face of said frosted surface of the glass panel whereby said rays are dispersed and reflected on to the strip and characters to be illuminated.

3. An illuminated indicator comprising a housing, an illuminating means within the housing, said housing being of opaque material and having a longitudinal slot in one wall thereof, means for supporting the glass panel with the edge portion thereof in register with said slot, an opaque strip having characters on one face thereof, the characters and panel on which they are mounted having different light absorbing properties, said strip being disposed relative to the glass panel so that the face thereof bearing the characters contacts with the rear face of the glass panel, the outer face of said glass panel being frosted and means for housing and directing illuminating rays through the slot and into the glass panel, whereby the light rays contacting with the inner face of the frosted surface will be dispersed and reflected on to said strip and the characters for illuminating the same.

4. An illuminated indicator comprising a glass panel, a strip having characters on one face thereof, the characters and strip on which they are mounted having different light absorbing properties, said strip being disposed relative to the glass panel so that the characters are visible through said glass panel, the outer face of said glass panel being frosted, and means for housing and directing illuminating rays against the rear face of said frosted surface of the glass panel whereby said rays are dispersed and reflected on to the strip and characters to be illuminated, said frosted surface of the glass panel having a transparent lacquer applied thereto and filling the cavities in the glass surface.

5 An illuminating indicator comprising a housing, an illuminating means within the housing, said housing being of opaque material and having a longitudinal slot in one wall thereof, means for supporting the glass panel with the edge portion thereof in register with said slot, an opaque strip having characters on one face thereof, the characters and panel on which they are mounted having different light absorbing properties, said strip being disposed relative to the glass panel so that the face thereof bearing

the characters contacts with the rear face of the glass panel, the outer face of said glass panel being frosted, whereby the light rays contacting with the inner face of the frosted surface will be dispersed and reflected on to said strip and the characters for illuminating the same, said frosted surface of the glass panel having a transparent lacquer applied thereto and filling the cavities in the glass surface.

FREDERICK L. SHELOR.

10