

Dec. 31, 1929.

H. F. WHITE

1,741,748

ILLUMINATED SIGN

Filed April 12, 1927

Fig. 1.

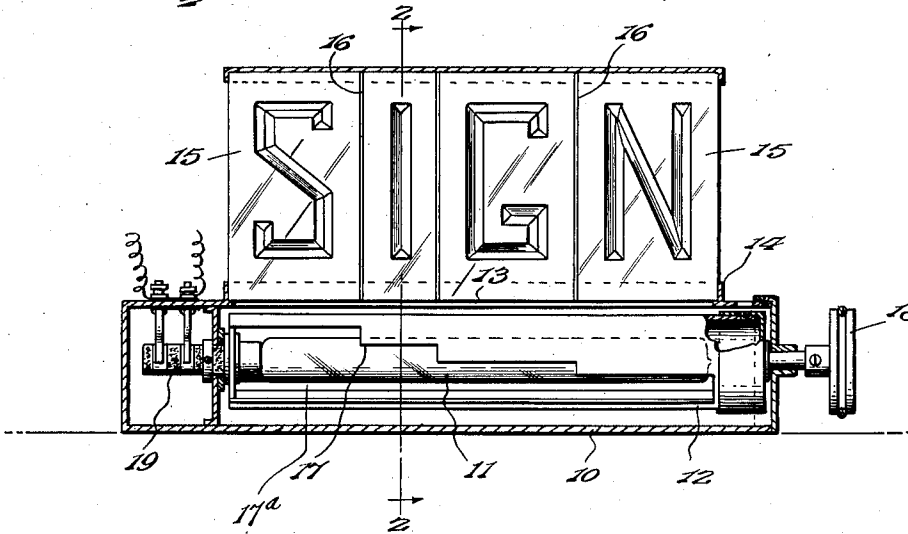

Fig. 2.

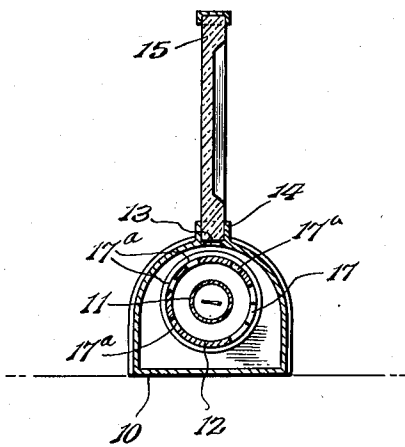
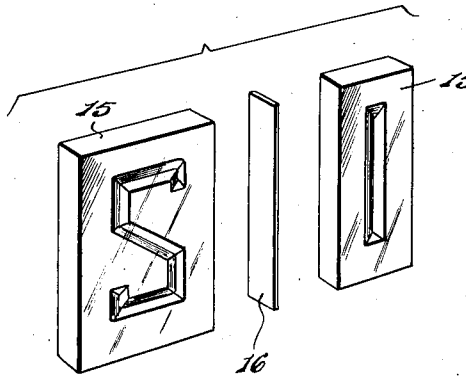

Fig. 3.



Inventor

Harry F. White.

By *Lacey & Lacey*, Attorneys

UNITED STATES PATENT OFFICE

HARRY F. WHITE, OF FRESNO, CALIFORNIA

ILLUMINATED SIGN

Application filed April 12, 1927. Serial No. 183,167.

This invention relates to display devices, such as signs, and provides an arrangement adapted to be illuminated in progression and darkened instantly, the parts as they become illuminated remaining lighted until the whole sign is displayed when the light is cut off to permit the instant darkening of the sign.

In accordance with the invention a light controlling member is provided and formed with a light emitting opening which progressively decreases in width and has its forward edge stepped and its rear edge straight, whereby the sign is progressively lighted and remains illuminated until fully displayed when it is darkened by the instant cutting off of the light.

While the drawing illustrates a preferred embodiment of the invention, it is to be understood that in adapting the means to meet specific needs and requirements, the design may be varied and such other changes in the minor details of construction may be resorted to within the scope of the invention as claimed, without departing from the spirit thereof.

For a full understanding of the invention and the merits thereof, reference is to be had to the following description and the drawing hereto attached, in which,—

Figure 1 is a front view of an illuminated sign embodying the invention, the housing being in section.

Figure 2 is a vertical, transverse sectional view on the line 2—2 of Figure 1.

Figure 3 is a detail perspective view of two transparent elements and the interposed light obstructing strips, the parts being separated.

Corresponding and like parts are referred to in the following description and designated in the several views of the drawings by like reference characters.

The numeral 10 designates a housing in which is located a filament lamp 11 and a light controlling member 12 which is in the nature of a cylinder or drum. The housing

10 is formed in a side with a slot 13, and a flange 14 surrounds the slots 13 and projects outwardly from the housing in line with the slot. A plurality of glass plates 15 are fitted within the space circumscribed by the flange 14 and, in consequence, present an edge to the slot 13, whereby to receive the rays of light projected through the slot from the lamp 11. The glass plates or transparent elements 15 bear parts of the data comprising the sign to be displayed. Since the light is admitted to the elements 15 in progression, it is necessary to interpose light obstructing strips 16 between each two adjacent elements to prevent the light being transmitted from one element to the other. In the preferable arrangement the data is cut into a surface of the elements 15, so as to become illuminated by the rays of light when projected into the elements from an edge thereof. Each of the elements 15 bears a part of the sign as a whole, and when the sign consists of a word, each element 15 bears a letter of such word. Obviously, if the sign consists of a phrase or sentence each of the elements 15 will bear a word or part of the matter to be displayed as a whole.

The light controlling member 12 is formed in a side with an opening 17 which is wide at one end and constricted at its opposite end, said opening progressively decreasing in width throughout its length and having its forward edge stepped and its rear edge straight, as indicated most clearly in Figure 1 of the drawing. That portion of the opening in line with the transparent element 15 bearing the letter S is of a length approximating the width of said element, and the portions of the opening in line with the other elements 15 are of a length corresponding to the width of the respective elements, thereby restricting the light to the several sign bearing elements. The light controlling member 12 is adapted to have a slow movement imparted thereto and since said member consists

of a cylinder or drum it has a rotary movement imparted thereto, and for this purpose a pulley 18 fitted to the projecting end of a journal is adapted to be connected to a suitable source of power, not shown. As the cylinder or drum is rotated the wide end of the opening 17 registers with the slot 13, thereby admitting of rays of light from the lamp 11 being projected into the first plate 15 to illuminate the matter borne thereby. As the cylinder or drum continues to rotate each of the elements 15 is successively illuminated, and the elements 15 remain lighted until the last element becomes lighted, so as to display the matter in its entirety, after which the sign is darkened by the cutting off of the light. This occurs the instant the opening 17 clears the light emitting slot 13. The duration of exposure of the sign depends upon the width of the opening 17, as will be readily appreciated, and this is modified by the speed at which the light controlling member 12 is driven.

The lamp 11 is of the straight line filament type, and current is supplied thereto from a suitable source by means of a contact mechanism 19, it being assumed that the lamp is mounted to rotate with the cylinder or drum 12.

Of course any type of lamp may be employed and when stationary the necessity for a contact mechanism, as at 19, will not exist. The drum 12 will be provided with other openings 17^a which are narrow and of uniform width to flash the sign off and on. When desired a color screen may be interposed between the sign and the source of light to change the color. It is observed that the sign may be changed by replacing the elements 15 by others bearing different letters or matter to be displayed.

Having thus described the invention, I claim:

An illuminated sign comprising a hollow housing adapted to rest upon a support, the upper portion of said housing being formed with a longitudinally extending slot, longitudinally extending flanges carried by said housing and projecting upwardly therefrom in spaced relation to opposite sides of the slot, transparent sign bearing elements above said housing having their lower portion fitting between said flanges and resting upon the housing in covering relation to the slot, opaque strips disposed between said elements, a support in said housing extending transversely in spaced relation to one end, a lamp socket journaled in said support axially of the housing, a lamp carried by said socket and extending longitudinally of the housing, a drum extending longitudinally in said housing and disposed about said lamp with one end engaged with said socket and rotatable about the same, a shaft extending from the other end of said drum and journaled in the

adjacent end of the housing and projecting outwardly therefrom, and turning means carried by the outer end of said shaft, the drum having a slot formed longitudinally therein and provided with a stepped marginal edge whereby as the drum rotates light may pass therefrom and upwardly through the slot in the housing to successively illuminate the sign bearing elements.

In testimony whereof I affix my signature.
HARRY F. WHITE.

70

75

80

85

90

95

100

105

110

115

120

125

130